

INSTALLATION AND OPERATION MANUAL

HIF 5X170FL

A Harmsco® Upflow Filter Containing 5 Filter Cartridges, 850 Square Feet of Media!



Harmsco® Filtration Products

With Patented Up-flow Filtration Technology

Installation

The following diagram shows typical installation procedure for Harmsco Industrial Filters:

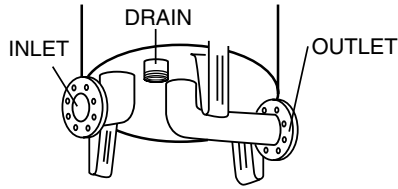

Models HIF-150-FL, HIF-200-FL
HIF-5X170-FL

1. Install pipe from pump to 4" flange marked "inlet".
2. Pipe outlet line to flange marked "outlet".
3. Install valve in drain line to 1-1/2" nipple marked "drain".
4. Tighten all flange bolts.

Notes:

- Shut-off valves should be installed on inlets, outlets and drain pipe to isolate the filter when necessary.
- Pressure gauges are recommended before and after the filter to easily calculate the pressure differential and determine when the cartridges should be cleaned or replaced.
- To protect against electrolysis, all filters should be grounded using grounding wire connected to hole in leg of filter. **Failure to ground the filter properly will void all warranties.**
- Use flange gaskets and or expansion/vibration coupling materials appropriate for your application.
- ALWAYS adhere to state and local plumbing codes and requirements for design and installation.

HIF 5X170FL Performance Curve *

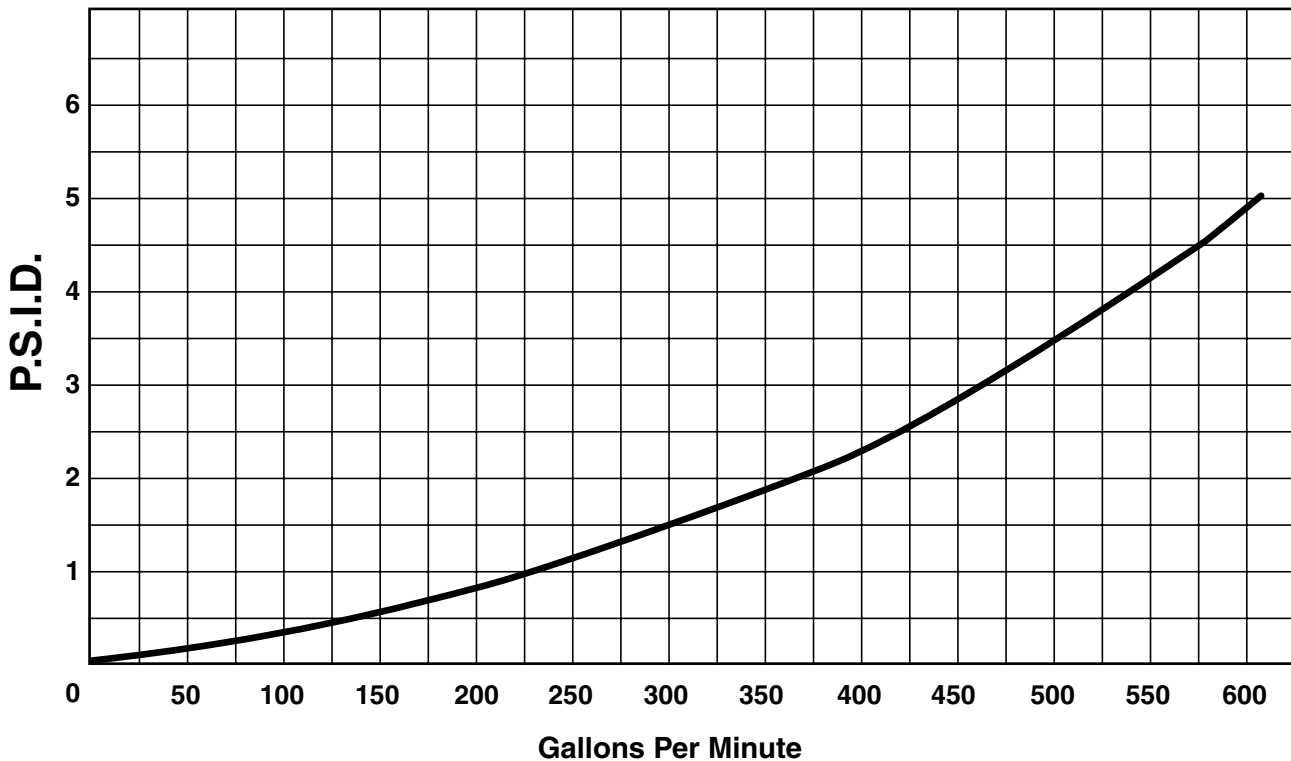

* Curve data developed using 20 micron cartridges with clean water.

HOW TO REMOVE AND REPLACE CARTRIDGES IN AN HIF 5X170FL

1. If applicable or necessary, turn off pump and isolate housing with shut-off valves.
2. Drain filter housing to relieve internal pressure.
3. Unscrew wing or hex nuts (Items #9 &10).
4. Lift lid (Item #11) from filter.
5. Remove retainer ring (Item #1).
6. Remove top stainless steel plate (Item #2) from unit.
7. Take off top seal (Item #3).
8. Lift out cartridges (Item #14) from filter housing.
9. Dependent on the application, replace or clean cartridges. If replacing the cartridges, transfer the nipples (Item #4) from the used cartridges to the new cartridges.
(Always follow State and Federal laws with regard to cartridge disposal.)
10. Place cartridges over boss (Item #8) on the sub base assembly in housing.
11. Replace rubber top seal (Item #3) properly.
12. Set stainless steel plate (Item #2) in place.
13. Replace retainer nut (Item #1) “hand tighten only”.
14. Replace lid (Item #11).
15. Lubricate studs with a grease suitable for your application.
16. Replace wing or hex nuts, alternate short and tall wingnuts (Items #9 & 10), alternately tightening nuts on opposite sides of lid.
17. Close drain valve.
18. Ensure all in-line valves are in open, flow-through position. (In parallel installations ensure that there is no reverse flow when opening valves).
19. If applicable, turn on pump.

LID REMOVAL WITH WING-NUT CLOSURE

Drain filter housing, remove wing-nuts and lid for easy access to filter cartridges. Alternate short and tall wingnuts when reassembling.



LID REMOVAL WITH HEX NUT CLOSURE

If hex nuts are used for lid closure, a speed wrench may be used for fast lid removal.

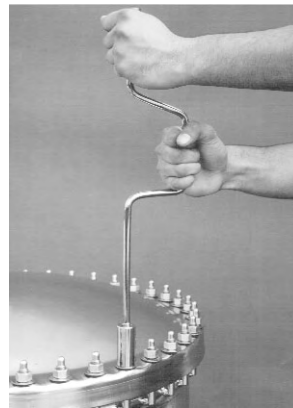

LID REPLACEMENT

Replace wing or hex nuts systematically, working opposite to one another. With wing nuts, “hand-tight” is normally sufficient. However, in extreme duty applications it may be necessary to tighten to 75 **inch lbs.** of torque. Over-tightening can cause damage to rim gaskets and top seals; do not use pry bars.

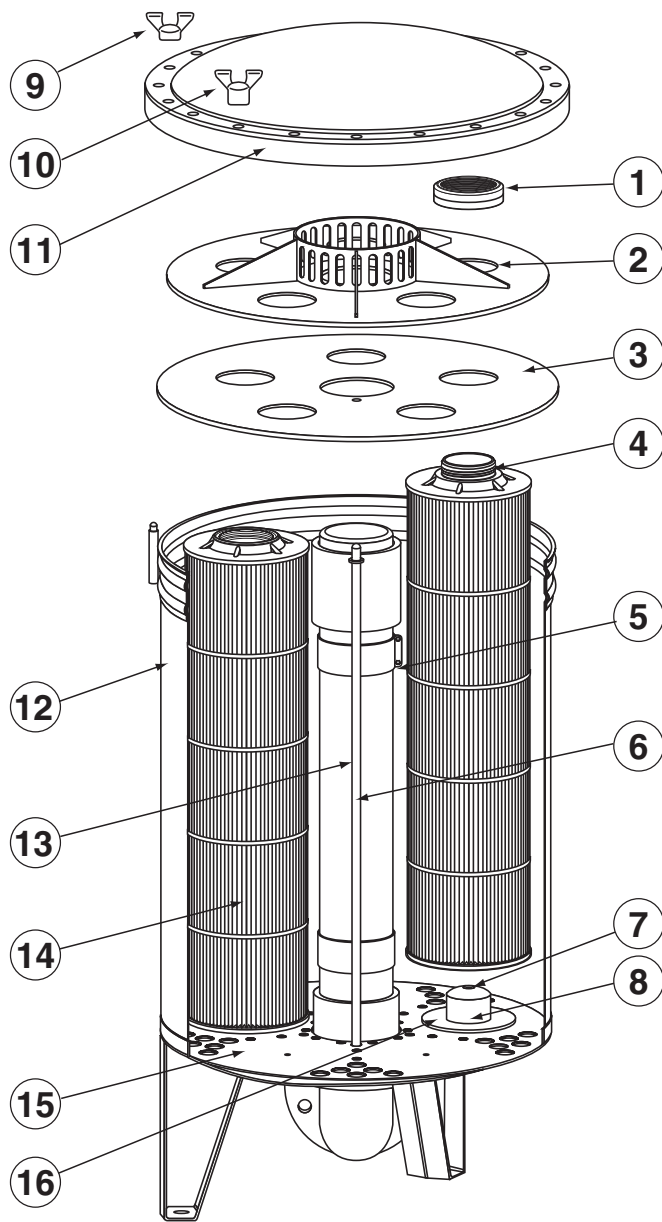

MODEL HIF 5X170FL			
ITEM	DESCRIPTION	PART NO.	QTY.
1	Ring, Cartridge Retainer	904	5
2	SS Top Disc, HIF 5X170FL	650SS	1
3	Seal, Top (HIF 5X170FL) EPDM	654-E	1
4	Nipple, Cartridge Retainer	908	5
5	Screw, 10-32x3/4 Pan HD SS	888	4
5	Nut, 10-32 Hex SS	889	4
6	Aligning Rod	658-4	1
7	Screw, 1/4-20 Hex HD SS	648	5
7	Nut, 1/4-20 Hex SS	649	5
8	Boss, Cartridge	641	5
9	Wing Nut, Brass	202-B	20
10	Wing Nut, Tall Brass	202-BT	20
11	Lid, 24" HIF	613-A	1
12	Tank Assembly, HIF 5X170FL	604-A	1
13	Standpipe, HIF 5X170FL	645-C	1
14	Cartridge, HC/170-*	HC/170-*	5
15	Sub Base Assembly HIF 5X170FL	642SS	1
16	Seal, Bottom (HIF 5X170FL)**	640-N	5

* Specify 0.35, 1, 5,10, 20, 50, 100, 150 microns, PP-HC/170-1, HC/170-EZ-CLEAN or activated carbon

**Natural Gum Rubber

*ALLOW 85" FROM FLOOR FOR OVERHEAD CLEARANCE

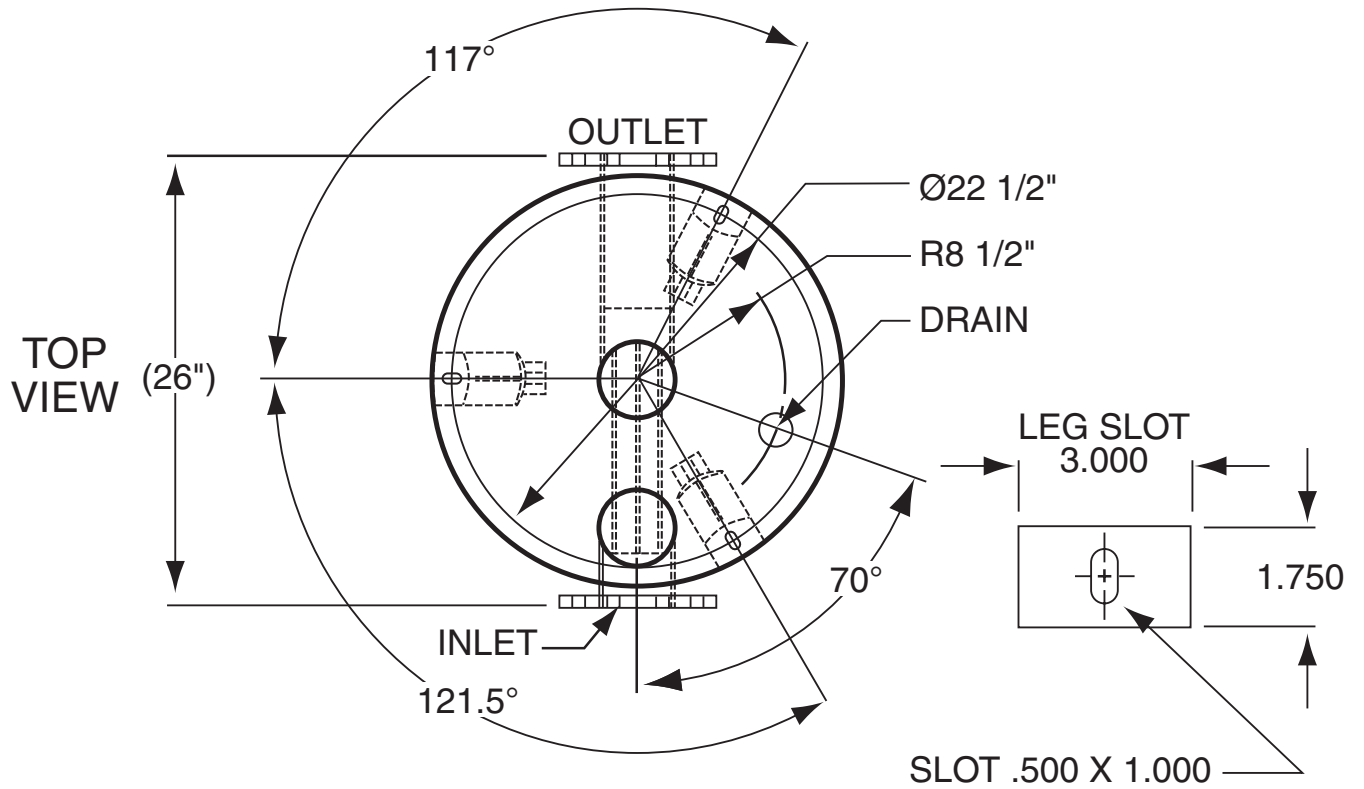
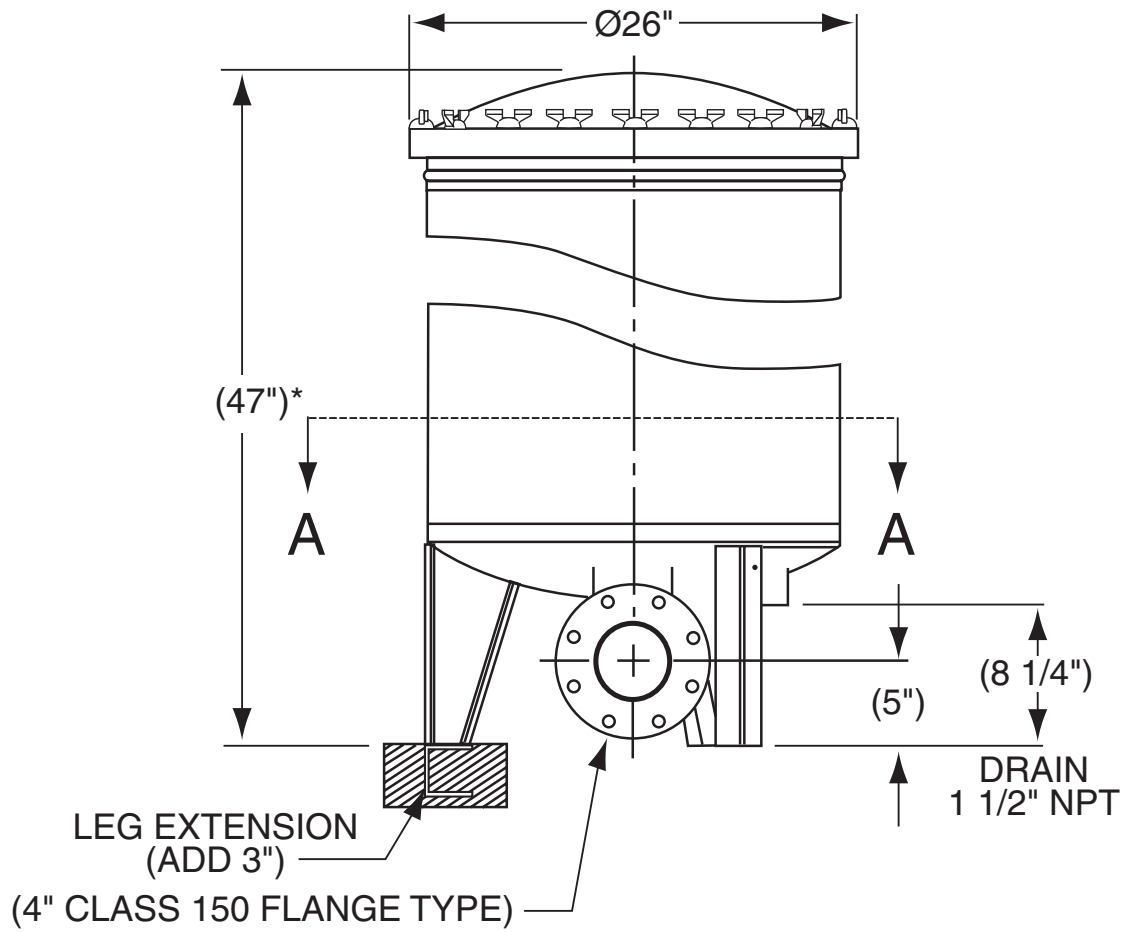



Replacement Cartridges

Standard pleated polyester filter elements

Cartridges rated for temperatures to 140°F (60°C). Polyester-Plus™ filter media is cleanable and cartridges are reusable in most applications and micron ratings. Cartridges can separate solids in liquids with a pH of 3 to 11. Packaged one per carton.

Poly-Pleat™ Cartridges are designed for drinking water applications to remove **Cryptosporidium** and **Giardia Cysts** and when one micron absolute rated filtration is required. Cartridges are rated for temperatures to 140°F (60°C). *Polypropylene filter media offers compatibility with many aggressive chemicals. Check compatibility charts for PVC center tubes and end caps.

*Temperature limits vary and depend on pressure and time under load.

Cartridge Product Code	Nominal Micron	Cartridge Dimensions				Ship wt./ctn. (One cartridge)
		L	x	OD	x ID	
HC/170-0.35	0.35	30-3/4"	7-3/4"	3" FPT	10 lbs.	
HC/170-1	1	30-3/4"	7-3/4"	3" FPT	10 lbs.	
HC/170-5	5	30-3/4"	7-3/4"	3" FPT	10 lbs.	
HC/170-10	10	30-3/4"	7-3/4"	3" FPT	10 lbs.	
HC/170-20	20	30-3/4"	7-3/4"	3" FPT	10 lbs.	
HC/170-50	50	30-3/4"	7-3/4"	3" FPT	10 lbs.	
HC/170-100	100	30-3/4"	7-3/4"	3" FPT	10 lbs.	
HC/170-150	150	30-3/4"	7-3/4"	3" FPT	10 lbs.	
HC/170-EZ-CLEAN**	N.R.	30-3/4"	7-3/4"	3" FPT	10 lbs.	



**100% Synthetic media to prefilter organic matter particulate.

Cartridge Product Code	Absolute Micron	Cartridge Dimensions				Ship wt./ctn. (One cartridge)
		L	x	OD	x ID	
PP-HC/170-1	1	30-3/4"	7-3/4"	3" FPT	10 lbs.	

Solid Block Activated Carbon With 5 Micron Prefilter

Product Code	Carbon content (lbs.)**	Capacity (gals.)**	Chlorine reduction*
HC/170-AC-5	10	100,000	90%-95% at 15 GPM/ cartridge

*Results may vary and are based on flow and other factors. **Approx.

CARTRIDGE CLEANING

Harmsco filter cartridges are cleanable and reusable in most applications and most micron ratings. For best results, clean cartridges when pressure differential is 12-15 psi above start-up differential. If cartridges are to be replaced allow pressure differential to climb to 25-30 psi above start-up differential or when flow has diminished to an unacceptable level, indicating cartridge is at capacity.

Cartridge Cleaning in Aqueous Applications: Clean cartridges with pressure nozzle using standard hose. Direct spray at an angle to remove particulate. Follow these directions for best results:

Oils in aqueous solution: Soak cartridges in a solution of tri-sodium phosphate or similar strong detergent (2 lbs. to ten gallons of water). Soak up to twelve hours. Rinse after soaking.

Organic matter and algae in aqueous solutions: Use tri-sodium phosphate or similar strong detergent as described above, plus one pint of liquid chlorine to kill organic matter and algae. Soak cartridges one hour or longer until surface is no longer *slippery*. Rinse after soaking.

Calcium & mineral deposits: Follow the directions for *oils* described above. Rinse cartridges thoroughly for approximately ten minutes in a solution of one part muriatic acid to twenty parts of water. Rinse cartridges thoroughly with water.

Caution:

Do not rinse cartridges with acid until oils and organic matter are removed. Use detergent first and follow with acid soak for mineral removal. Flush cartridges with water after muriatic or tri-sodium phosphate baths.

It is not advisable to clean Harmsco cartridges when filtering petroleum-base liquids, toxic substances, or when using one micron and submicron cartridges or activated carbon.

Harmsco Inc. Industrial Filters Limited Warranty

- Harmsco, Inc. warrants its line of Industrial Filters to be free of defects in material and workmanship for a period of one year from the date of installation.
- The warranty for Industrial Filters ordered with special coatings is limited only to the re-coating of the defective parts due to failure in materials or workmanship for one year from date of installation.
- This warranty does not cover any equipment purchased for use in applications in which the product is not suited. It is the responsibility of the buyer to determine if a product is suitable for a particular application.
- THIS WARRANTY EXCLUDES THE FOLLOWING:**
 - Any fresh water unit installed for salt water use.
 - Damage caused by improper installation, operation or care.
 - Chemical attack.
 - Modification or alteration by other than Harmsco employees.
 - Rubber type parts and normal wear items i.e. "O" rings, rim gaskets, wing-nuts, pipe caps, holding rods.
 - Any costs of labor or expenses expended in the removal and/or installation of unit, or any surrounding device.
 - Damage caused by galvanic or electrolytic attack.
 - Altering or removing the Harmsco, Inc. information label.
 - Any unit not grounded.
- Service under this warranty is to be provided by the distributor who sold the unit to the user. If the distributor is unable to provide warranty service, contact:

Harmsco, Inc., P.O. Box 14066
North Palm Beach, Florida, 33408, U.S.A.
Phone: (561) 848-9628 • Fax: (561) 845-2474

A Returned Goods Authorization (RGA) number must be received from the above office and placed on all shipments to and correspondence with Harmsco, Inc. Please be prepared with the following information: 1. Model number and serial number. 2. Date of installation. 3. Name of installer 4. Nature of problem. 5. Your address and telephone number.

Available from:

Harmsco® is a registered trademark of Harmsco, Inc.
©2001 Harmsco, Inc. 018 4/07

Toll Free: **(800) 327-3248**
 Fax: **(561) 845-2474**
 Local: **(561) 848-9628**
 E-mail: **sales@harmsco.com**



Harmsco® Filtration Products

P.O. Box 14066, North Palm Beach, Florida 33408